 Directorate for Payments	Policy Area Agriculture and Rural Development	DEPARTMENT FOR PUBLICITY AND AUTHORISATION OF PROJECTS	
	Version No: 1.1		
Ministry of Agriculture and Rural Development of Montenegro		Document: DP-DPAP- 00-29	Page 1 of 5

DP-DPAP-00-29 - Invitation for the offers/quotations

Project Title - Name of the investment: Supply of new technological equipment

Date of invitation: January 29th 2019

Number and date of the IPARD Contract 321-2301/18-12 dated December 19th 2018

Dear Supplier(s),

1. You are invited to submit your offer/quotation(s) with exact prices and quantities for the supply of the following items:

(i) Name of the item : Automatic machine for packaging meat products ;

(ii) Type of the item: Thermoforming machine for packaging;

(iii) Model of the item: /;

(iv) Information on technical specification (minimal technical specification) for each item, which is contracted (horse power, operational width, engine speed, bearing capacity, bill of quantities, etc.)

- The equipment is foreseen for production of packages with deep extrusion – hot deep extrusion of the lower layer.
- Machine must be adapted for electrical greed in the Mediteranea facility, i.e. voltage 400 V i frequency od 50 HZ
- Machine must be adapted for vacuum packaging of the products, as well as in the modified atmosphere
- It is foreseen work with OPA/PE, upper layer up to 80 microns tick and lower layer up to do 240 microns of thickness
- Needed capacity is 5 do 7 takt/min za for vacuum packaging
- Parts of the machine should be constructed from the stainless steel, sanitary PE and other materials that can be used in the food industry
- Hidraulic pump in the machine should be with minimum capacity of 100 m3/h
- The machine must be equipped with automatic system for edge cutting

 Directorate for Payments	Policy Area Agriculture and Rural Development	DEPARTMENT FOR PUBLICITY AND AUTHORISATION OF PROJECTS	
	Version No: 1.1		
Ministry of Agriculture and Rural Development of Montenegro		Document: DP-DPAP-00-29	Page 2 of 5

- Tools for thermoforming which will be delivered with the machine should be of the following dimensions: 240 mm x 130mm, with the possibility of the minor deviation (up to 5 mm), as follows :

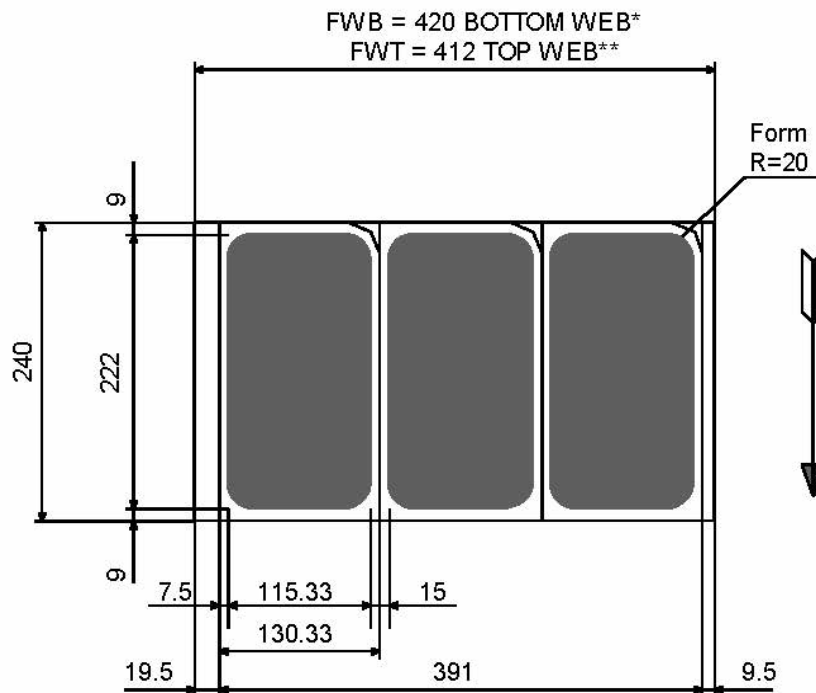

- Due to the limitation of the room in which is foreseen installation of the machine, maximum dimensions of the machine should be: 4,5m of length i 1,3 m in width.
- Autorised service for maintenance in warranty period, as well as upon thi period, should be in Montenegro or in any neighboring country
- Maximal deadline for delivery is 100 days

Note that the highest price for listed items is 61.500 EUR and that only the offers with the lowest or the same price will be selected for the evaluation procedure.

2. You must quote for all items under this invitation. Price quotations will be evaluated for all the items together and contract awarded to the company offering the lowest evaluated total cost of all the items.

 Directorate for Payments	Policy Area Agriculture and Rural Development	DEPARTMENT FOR PUBLICITY AND AUTHORISATION OF PROJECTS	
	Version No: 1.1		
Ministry of Agriculture and Rural Development of Montenegro		Document: DP-DPAP- 00-29	Page 3 of 5

Your price quotation must include the name of the purchaser to whom is submitted (name of potential purchaser), must be dated and stamped and should be submitted by post, personally or facsimile or electronically at the following address:

“MEDITERANEA” DOO

Donji kraj bb, 81250 Cetinje Crna Gora

E-mail : spadijeri@t-com.me

Broj telefona : +382 67 278 283

One copy of your quotation(s) may be addressed and submitted also to Directorate for payment:
E-mail: dostavljanje.ponuda@mpr.gov.me

3. Your quotation in duplicate and in Montenegrin language, should be accompanied by adequate technical documentation and catalogue(s) and other printed material or pertinent information (in na English language) for each item quoted, including names and addresses of firms providing service facilities in Montenegro of neighboring country).

4. The deadline for receipt of your quotation (s) by the Purchaser at the addressed indicated in Paragraph 2 is: 14.02.2019

5. You quotation(s) should be submitted as per the following instructions:

(i) PRICES: The prices should be quoted for delivery **CIP** (Cetinje) for imported goods or **EXW** for domestically supplied goods plus the price of delivery to the place of destination, according to INCOTERMS, 2010. Prices should be quoted in Euro.

(ii) EVALUATION OF QUOTATIONS: Offers determined to be substantially responsive to the technical specifications will be evaluated by comparison of their prices.

In evaluating the quotations, the Purchaser will determine for each proposal the evaluated price by adjusting the price quotation by making any correction for any arithmetical errors as follows:

 Directorate for Payments	Policy Area Agriculture and Rural Development	DEPARTMENT FOR PUBLICITY AND AUTHORISATION OF PROJECTS	
	Version No: 1.1		
Ministry of Agriculture and Rural Development of Montenegro		Document: DP-DPAP- 00-29	Page 4 of 5

(a) where there is a discrepancy between amounts in figures and in words, the amount in words will govern;

(b) where is a discrepancy between the unit rate and the line item total resulting from multiplying the unit rate by the quantity, the unit rate as quoted will govern;

(c) if a Supplier refuses to accept the correction, his quotation will be rejected.

In addition to the quoted price, the evaluated price shall include:

- All custom duties, import and any other taxes or fees applicable for goods imported in Montenegro, and

Also, each offer/quotation must clearly indicate if the Value Added Tax (VAT) is included in the price and the amount and percentage of the VAT. The VAT percentage should be indicated for the country of Supplier.

(iii) AWARD OF PURCHASE ORDER: The award will be made to the bidder offering the lowest evaluated price and that meets the required standards of technical and financial capabilities. The successful bidder will sign a Contract with the Purchaser. The Contract has to be signed by both parties and stamped and it must include the stipulations for:

- the date of signing,
- the exact information of the name of the purchaser and the supplier,
- the name of the investment,
- the total price of the investment in figures and in the words,
- the deadline of the finalization and/or delivery of the investment,
- the warranty deadline and conditions

(iv) VALIDITY OF THE OFFER: Your quotation(s) should be valid for at least a period of forty five (45) days from the deadline for receipt of quotation(s).

8. Further information can be obtained from:

Ivan Špadijer
Contact person u „Mediteranea“ doo

 Directorate for Payments	Policy Area Agriculture and Rural Development	DEPARTMENT FOR PUBLICITY AND AUTHORISATION OF PROJECTS	
	Version No: 1.1		
Ministry of Agriculture and Rural Development of Montenegro		Document: DP-DPAP- 00-29	Page 5 of 5

Tel no: +382 67 278 283

E-mail: spadijeri@t-com.me

Sincerely,

Executive manager

Marija Špadijer

